

UNITED STATES PATENT AND TRADEMARK OFFICE

BEFORE THE PATENT TRIAL AND APPEAL BOARD

OTICON MEDICAL AB; OTICON MEDICAL LLC; WILLIAM
DEMANT HOLDING A/S
Petitioner,

v.

COCHLEAR LIMITED
Patent Owner.

Case IPR2019-00975
Patent 9,838,807 B2

Before BARRY A. GROSSMAN, JAMES A. WORTH, and MICHAEL L.
WOODS, *Administrative Patent Judges*.

WORTH, *Administrative Patent Judge*.

DECISION
Granting Institution of *Inter Partes* Review
35 U.S.C. § 314

I. INTRODUCTION

On April 15, 2019, Oticon Medical AB; Oticon Medical LLC; William Demant Holding A/S (“Oticon” or “Petitioner”) filed a Petition (Paper 1, “Pet.”) requesting an *inter partes* review of claims 1–12, 14, 16, 17, 25, 28, 33–35, 37–41, and 45–47 (the “challenged claims”) of U.S. Patent No. 9,838,807 B2 (Ex. 1001, “the ’807 patent”). On July 20, 2019, Cochlear Ltd. (“Cochlear” or “Patent Owner”) filed a Preliminary Response (Paper 13, “Prelim. Resp.”).

Institution of an *inter partes* review is authorized by statute when “the information presented in the petition filed under [35 U.S.C. §] 311 and any response filed under [35 U.S.C. §] 313 shows that there is a reasonable likelihood that the petitioner would prevail with respect to at least 1 of the claims challenged in the petition.” 35 U.S.C. § 314(a). For the reasons set forth below, we determine that Petitioner has demonstrated that there is a reasonable likelihood that claims 1–12, 14, 16, 17, 25, 28, 33–35, 37–41, and 45–47 are unpatentable, and we institute an *inter partes* review of claims 1–12, 14, 16, 17, 25, 28, 33–35, 37–41, and 45–47 based on the grounds set forth in the Petition.

A. Related Matters

The parties note as related litigation in federal district court, *Cochlear Ltd. v. Oticon Medical AB et al.*, No. 3:18-cv-06684 (D.N.J., filed April 13, 2018). *See* Pet. 1; Paper 6, 2.

B. The ’807 Patent (Ex. 1001)

The ’807 patent is titled “Bone Anchor Fixture for a Medical Prosthesis” and relates to “hearing devices and, more particularly, to anchoring elements for bone anchored hearing devices.” Ex. 1001, code

(54), 1:19–20. The '807 patent discloses a need in the art for more effective osseointegration between an implant screw and the skull bone, to implant in patients having impaired bone quality and to allow loading of an implant at an earlier stage. *Id.* at 1:62–67.

In one embodiment, the '807 patent discloses a tapered anchoring fixture with an apical portion, a first threaded portion, and a second threaded portion, where the second threaded portion has an inner diameter greater than that of the first threaded portion. *Id.* at 2:16–28. The Specification discloses that “[t]his configuration provides compression in the radial direction on the skull bone to improve the initial stability of the anchoring fixture.” *Id.* at 2:13–15.

In another embodiment, the '807 patent discloses a flange adjacent the second threaded portion, where the flange comprises a planar bottom portion adapted to rest on top of the skull when the fixture is implanted. *Id.* at 2:24–27. The '807 patent discloses that a person installing the fixture may drill a hole into the skull bone, where the hole has a diameter greater than the inner diameter of the first portion and less than the outer diameter of the second portion. *Id.* at 2:36–42.

Figure 2 of the '807 patent is reproduced below:

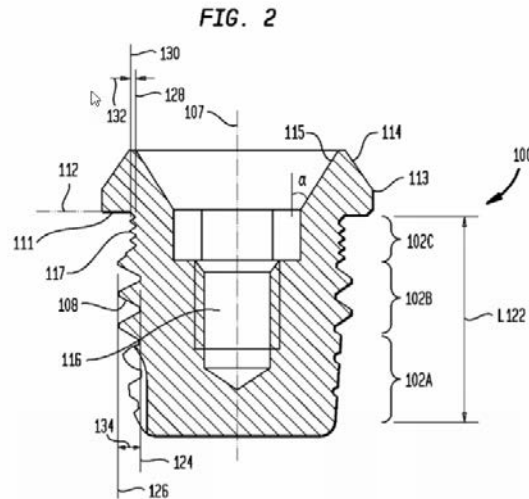

Figure 2 is a cross sectional view of one embodiment of the anchoring fixture. *See Ex. 1001, 2:49–56.* As shown in Figure 2, main body 102 comprises a distal tapered apical portion 102A and a straight, generally cylindrical body comprising two portions, a first portion 102B and a second portion 102C. *Id.* at 3:60–63.

C. Illustrative Claim

Claims 1 and 8 are the independent claims challenged in the Petition.

Claim 1, reproduced below, is illustrative of the subject matter:

1. An anchoring fixture for anchoring a prosthesis to a skull bone comprising:
 - a screw thread apparatus including a screw thread having a varying outer diameter;
 - a flange configured to function as a stop for the anchoring fixture adapted to rest on top of the bone when the anchoring fixture is implanted into the bone; and
 - a circumferential groove located, with respect to a side of the flange, on the anchoring fixture on a threaded side of the anchoring fixture,wherein the anchoring fixture is configured for anchoring a hearing prosthesis component to the skull bone at a location behind an external ear so that sound is transmitted from the hearing prosthesis via the skull bone to the cochlea.

Ex. 1001, 5:56–6:3.

D. The Prior Art

Petitioner relies on the following prior art:

WO 98/55049, pub. Dec. 10, 1998 (Ex. 1006, “Håkansson”);

US 6,981,873 B2, iss. Jan. 3, 2006 (Ex. 1005, “Choi”);

WO 2006/065205 A1, pub. June 22, 2006 (Ex. 1008, “Brånemark”);

US 7,074,222 B2, iss. July 11, 2006 (Ex. 1007, “Westerkull ’222”);

US 7,116,794 B2, iss. Oct. 3, 2006 (Ex. 1003, “Westerkull ’794”).

E. Prior Art and Asserted Grounds

Petitioner asserts that claims 1–12, 14, 16, 17, 25, 28, 33–35, 37–41 and 45–47 would have been unpatentable on the following grounds (Pet. 6):

| Claim(s) Challenged | 35 U.S.C. § | Basis |
|---|--------------------|--|
| 1–12, 14, 16, 25, 28, 33–35, 38, 39, 45, 46 | § 103 | Westerkull ’794 and Choi |
| 17 | § 103 | Westerkull ’794, Choi, and Håkansson |
| 37, 47 | § 103 | Westerkull ’794, Choi, and Westerkull ’222 |
| 28, 40, 41 | § 103 | Westerkull ’794, Choi, and Brånemark |

II. ANALYSIS

A. Claim Construction

Because the Petition was filed after November 13, 2018, we construe the challenged claims by applying “the standard used in federal courts, in

other words, the claim construction standard that would be used to construe the claim in a civil action under 35 U.S.C. [§] 282(b), which is articulated in *Phillips [v. AWH Corp., 415 F.3d 1303 (Fed. Cir. 2005) (en banc)]*.” See Changes to the Claim Construction Standard for Interpreting Claims in Trial Proceedings Before the Patent Trial and Appeal Board, 83 Fed. Reg. 51,340, 51,343–44 (Oct. 11, 2018) (to be codified at 37 C.F.R. pt. 42). Under *Phillips*, the words of a claim are generally given their “ordinary and customary meaning,” which is the meaning they would have to a person of ordinary skill in the art at the time of the invention, in light of the specification and prosecution history. See *Phillips*, 415 F.3d at 1312–13.

Petitioner requests construction of the following claim phrases and refrains from construing others: the preamble; “circumferential groove” (claim 1); “means for exerting a compression onto the skull bone in a radial direction to stabilize the fixture in the skull bone” (claim 35); “wherein the anchoring fixture is configured for anchoring a hearing prosthesis component to the skull bone at a location behind an external ear so that sound is transmitted from the hearing prosthesis via the skull bone to the cochlea” (claim 1); “wherein the bone fixture is configured to anchor a hearing aid prosthesis to a skull bone at a location behind an external ear of a recipient so that sound is transmitted from the hearing prosthesis via the skull bone to the cochlea” (claim 8). Pet. 18–25. Patent Owner does not request construction of any terms. Prelim. Resp. 15.

For purposes of this decision on institution, we construe the claim phrases in dispute as follows.

the preamble: “for anchoring a prosthesis to a skull bone” (claim 1)

Petitioner argues that the claim phrase “for anchoring a prosthesis to a skull bone” is a statement of intended use. Pet. 19. Patent Owner does not

comment on the claim phrase. For purposes of this decision, we agree with Petitioner that the claim phrase describes an intended use of the device, i.e., to anchor a prosthesis, because we have not been directed to any evidence that persuades us that the preamble is limiting. *See Allen Eng'g Corp. v. Bartell Indus., Inc.*, 299 F.3d 1336, 1346 (Fed. Cir. 2002).

“circumferential groove” (claim 1)

Petitioner argues that the claim phrase “circumferential groove” means “a channel, distinct from the screw thread and distinct from the flange, extending around the cylindrical portion of the main body of the anchor, having an inner diameter and an outer diameter.” Pet. 20. Petitioner also asserts that a person of ordinary skill would understand that a circumferential groove is provided to “exert a compressive radial force on the skull bone to improve stability of the anchoring fixture.” *Id.* (citing Ex. 1013, 3; Ex. 1002 ¶ 36). Patent Owner does not comment on the claim phrase. However, Petitioner acknowledges that in the District Court, Patent Owner argued that the “circumferential groove” means “a long narrow channel around part or all of a circular periphery of the implant.” *See* Pet. 20 (citing Ex. 1012, 2).

The District Court construed “circumferential groove” to mean “a narrow channel extending around the cylindrical periphery of the main body of the implant.” Ex. 3001, 33. For purposes of this decision, we adopt the District Court claim construction as consistent with the ordinary meaning of the terms “circumferential” and “groove.” We decline at this juncture to read additional meaning into the claim phrase, absent persuasive arguments that “circumferential groove” is a term of art, or that the Specification provides a special meaning or otherwise limits the phrase, or that there is a prosecution history disclaimer. Nevertheless, we invite the parties to further

brief the construction of “circumferential groove.” In particular, the parties may wish to address whether the term “circumferential,” which the District Court interprets to correspond to a periphery, would refer to the widest portion of the device that is inserted into the skull, i.e., below the flange, or rather to any outer portion.

“means for exerting a compression onto the skull bone in a radial direction to stabilize the fixture in the skull bone” (claim 35)

Petitioner argues that this claim phrase is “means” language that falls under 35 U.S.C. § 112(6). Pet. 22. On this record, we agree that the claim phrase does not recite structure other than “means” and therefore falls under 35 U.S.C. § 112(6). Petitioner argues that, to the extent the Specification discloses corresponding structure, the corresponding structure would be portion 102C because the Specification discloses that “the wider second portion of the fixture, i.e., the portion next to the flange, provides a certain compression to the bone, specifically the cortical bone, in the radial direction of the hole.” Pet. 23 (citing Ex. 1001, 3:25–29). Patent Owner does not comment on the claim phrase at this time. For purposes of this decision, we determine that portion 102C is corresponding structure because the Specification discloses that it provides a radial force, which is the recited function. Ex. 1001, 3:25–29

“wherein the anchoring fixture is configured for anchoring a hearing prosthesis component to the skull bone at a location behind an external ear so that sound is transmitted from the hearing prosthesis via the skull bone to the cochlea” (claim 1); “wherein the bone fixture is configured to anchor a hearing aid prosthesis to a skull bone at a location behind an external ear of a recipient so that sound is transmitted from the hearing prosthesis via the skull bone to the cochlea” (claim 8)

Petitioner argues that the “wherein” clauses are statements of intended use. See Pet. 24–25. Patent Owner does not comment on the claim phrases

at this time. For purposes of this decision, we determine that the “wherein” clauses describe an intended use of the implant fixture, i.e., to anchor a hearing aid prosthesis in a particular place. None of the parties have identified structural consequences of this use. We observe that the length of the fixture might differ based on the bone in which it is placed. *See, e.g.*, Ex. 1007, 1:62–65 (skull bone is thinner than jaw bone). Nevertheless, the parties have not argued for a structural meaning of these phrases at this time. Accordingly, we need not construe the claims further at this time. *See Vivid Techs., Inc. v. Am. Sci. & Eng’g, Inc.*, 200 F.3d 795, 803 (Fed. Cir. 1999) (claims are construed only to the extent necessary to resolve a dispute).

*B. Patent Owner’s Arguments Regarding 35 U.S.C.
§ 325(d)*

Patent Owner argues that the Board should deny institution under 35 U.S.C. § 325(d) because the Petition is based on substantially the same prior art and arguments already considered by the Office during prosecution of the ’807 patent or its parent application, the ’083 Application. Prelim. Resp. 16–17 (citing *Becton, Dickinson & Co. v. B. Braun Melsungen AG*, IPR2017-01586, Paper 8 at 17–18 (PTAB Dec. 15, 2017) (precedential (“*Becton Dickinson*”))). As described in more detail below, Patent Owner argues that the Petition’s prior art is the same or cumulative of the prior art analyzed by the Office during prosecution of the application that issued as the ’807 patent or its parent application, the ’083 Application; the invalidity arguments overlap with arguments evaluated during prosecution; and the Petition does not point out how the Office erred in evaluating the prior art or why reconsideration is warranted. *Id.* at 16–23. We address Patent Owner’s contentions for each reference in turn, and then analyze the § 325(d) issue in view of the factors announced in *Becton Dickinson*.

1. Analysis under Becton Dickinson factors

In evaluating whether to exercise our discretion under § 325(d), we weigh the following non-exclusive factors: (a) the similarities and material differences between the asserted art and the prior art involved during examination; (b) the cumulative nature of the asserted art and the prior art evaluated during examination; (c) the extent to which the asserted art was evaluated during examination, including whether the prior art was the basis for rejection; (d) the extent of the overlap between the arguments made during examination and the manner in which Petitioner relies on the prior art or Patent Owner distinguishes the prior art; (e) whether Petitioner has pointed out sufficiently how the Examiner erred in its evaluation of the asserted prior art; and (f) the extent to which additional evidence and facts presented in the Petition warrant reconsideration of prior art or arguments. *Becton Dickinson*, at 17–18.

Factors a) and b) The similarities and material differences between the asserted art and the prior art involved during examination; the cumulative nature of the asserted art and the prior art evaluated during examination

Patent Owner argues that Westerkull '794, Westerkull '222, and Håkansson were expressly considered during prosecution of the '807 patent and the '803 Application. Prelim. Resp. 17. However, Choi has never before been considered by the Office. Petitioner relies on Choi for the circumferential grooves of independent claims 1 and 8. *See, e.g.*, Pet. 44–45, 48. Patent Owner argues that Choi is cumulative over Härle, which was considered during prosecution. Prelim. Resp. 18–19. Choi was not previously of record. We disagree for the reasons that follow.

(i) Overview of Choi

Choi is titled “Dental Implant and Head for a Compaction Drill” and relates particularly to a dental implant that can immediately brace artificial dental structures, and also can accomplish enhanced bonding between a bone tissue and the implant. Ex. 1005, code (54), 1:6–13. Choi also relates to a head for a compaction drill specially designed for the implant. *Id.* at 1:13–15.

Choi describes an aesthetic problem with dental implants that required one surgery, i.e., there was a metal portion of the implant exposed above the gum line. *Id.* at 1:26–28. Choi also describes other problems in the art of dental implants, i.e., limited surface area and stress distribution around the screw. *Id.* at 3:38–40.

Figure 6 of Choi is depicted below:

200

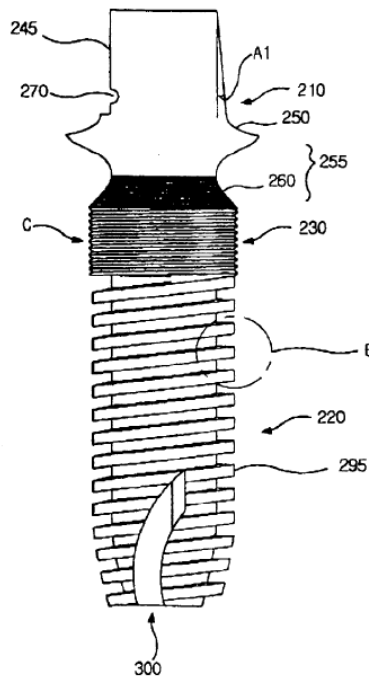

Figure 6 of Choi depicts an enlarged side view for illustrating a perspective view for showing a preferred embodiment of Choi's dental implant. *Id.* at 6:38–42.

Choi discloses a dental implant with fixture portion 220, settling portion 230, and abutment portion 210. *Id.* at 7:7–12. Figure 9 (not shown) is an enlarged side view of Figure 6. *Id.* at 6:48. In the embodiment of Figures 6 and 9, Choi discloses a number of minute screwed grooves 290 are formed on the surface of the settling portion 230. *Id.* at 9:1–2. The screwed grooves 290 have the pitch (D_2) of about 0.15 to about 0.25 mm, preferably about 0.20 mm and the thread angle (A_3) of about 80 to about 120°. *Id.* at 9:3–5. The settling portion 230, like a wise crystal module, can disperse the stress on the implant 200 into the cortex-bone of the jawbone and minimize osteolysis so as to increase the bond with the bone. *Id.* at 9:5–7; *see also id.* at 9:8–16.¹

(ii) Overview of Härle

Härle is titled “Osteosynthetic Force Transmitting Member” and relates to the art of uniting parts of fractured bones by mechanical means, such as by plates or the like, and more particularly, to improvements in osteosynthetic force transmitting members or connectors which can be used, for example, to affix parts of broken bones to plates or other types of positioning means. Ex. 2010, code (54), 1:5–10. Härle described problems in the art of bone screws, when a partially or fully threaded pin was called upon to maintain plates, rods, bars, or other accessories for holding bones or

¹ By comparison, a different portion of Choi discloses a pitch of 0.15 to 0.25 μm for screwed grooves on the settling portion. *See id.* at 4:67–5:3. The parties are invited to brief whether Choi intended to disclose millimeters instead of micrometers in column 5, or vice versa.

fragments of bones in a desired position, temporarily or permanently. *See id.* at 1:37–46. In particular, the portion of the prior art screws that extended out of a bone was subject to mechanical stresses, i.e., bending, flexing, or shearing stresses. *Id.* at 2:7–17. The portion of the prior art screws that penetrated the bone was subjected to longitudinal or tensional stresses. *Id.* at 2:2–7. The provision of an external thread on a screw weakened the shank adjacent the head and the likelihood of breakage of bone screws generated numerous problems, and the broken off portion would have to be removed. *Id.* at 2:24–3:47. If a break developed, it was normally very close to the exposed surface of the bone (i.e., at the location where the shank has penetrated into a bone or a bone fragment) so that it was difficult to extract the anchored portion of the shank from the bone. *Id.* at 2:28–32.

Härle disclosed an osteosynthetic force transmitting member comprising a first section to force-lockingly engage a bone, a second section with means for coupling the force transmitting member to an accessory (e.g., a plate), and an intermediate section constituting a weakened part that is more likely to break than the first or second section when subjected to stress. *Id.* at 4:32–42. According to Härle, upon breakage, bone would not have to be removed to access the first section, *inter alia*, because the intermediate section could be configured to receive and transmit pressure to the first section. *Id.* at 4:50–57, 5:10–30.

Figure 5 of Härle is reproduced below:

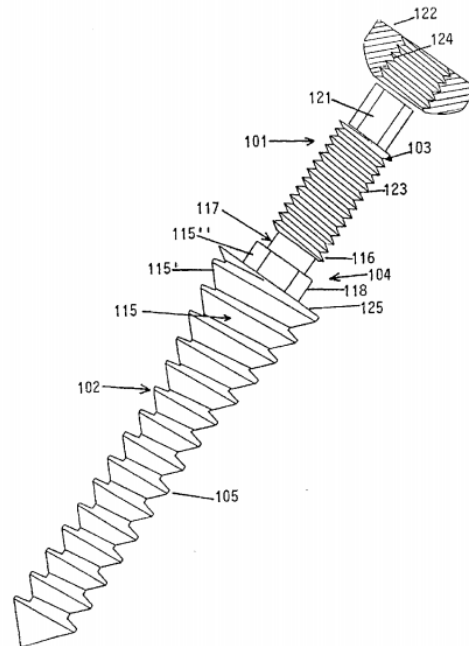

FIG. 5 is an exploded elevational view of a two-piece force transmitting member of an embodiment of Härle designed to penetrate into a vertebra. *Id.* at 6:45–48.

First section 102 has treads 105. *Id.* at 9:60–64. Second section 103 has treads 123, which can be used to drive first section 102 into a vertebra. *Id.* at 10:15–19. Intermediate section 104 includes item 115 with threaded component 115', section 115" which can be engaged by a tool to first section 102 in the event of a breakage, and breakage section 117. *See id.* at 9:63–10:4. Weakened or breakage zone 117 is obtained by providing the external surface of intermediate section 104 with a circumferentially complete groove disposed between the polygonal part 115" of component 115 and component 116. *Id.* at 10:10–14.

(iii) *Analysis*

As discussed in more detail with respect to *Becton Dickinson* factors c) and d) below, the Examiner relied on Härle during prosecution of the parent '083 Application for an anticipation rejection. Ex. 1010, 222, 305.

Choi is not cumulative over Härle because Choi's circumferential groove and Härle's circumferential groove are different structures that serve different purposes.

Patent Owner argues that Härle's grooves 123 are similar to Choi's minute screwed grooves on settling portion 230. Prelim. Resp. 18. However, Härle discloses a screw or fastener to connect pieces of bone to plates or other accessories. Ex. 2010, 4:32–42. By contrast, Choi discloses a fixture for an implant, and specifically for a tooth implanted into the skull bone. Ex. 1005, 7:7–12. Choi's circumferential grooves are also designed to be placed within the cortical bone. *See id.* at 9:1–16. Choi is thus solving a problem that is closer to that of the '807 patent. *See, e.g.*, Ex. 1001, 2:3–4.

Härle's grooves 123 are placed on a narrower portion of the screw than that portion with threads 115. *See In re Mraz*, 455 F.2d 1069 (CCPA 1972) (what is shown clearly in patent drawings is not disregarded); *In re Heinle*, 342 F.2d 1001 (CCPA 1965) (relying on drawing to show relative proportions). This is in contrast to Choi's grooves, which are placed on a wider portion of the screw than the portions with Choi's other screw threads. *See Ex. 1005*, 8:60–67. Choi's circumferential grooves are placed on a portion of the implant that has a wider diameter (of between 4.0 mm and 4.2 mm), as compared to the portion of the implant with Choi's other screw threads (which has a diameter of between 2.0 mm and 4.0 mm). *Id.*

Further, Härle's grooves 123 are intended to allow the surgeon to drive first portion 102 into the bone (*see Ex. 2010*, 10:15–19), which is a

completely different purpose than Choi's circumferential grooves, which are designed to sit in the bone to disperse stress on the bone and to prevent bone resorption (osteolysis) after implantation into the bone. *See* Ex. 1005, 9:1–16. The small size of Choi's grooves is also significant, with a pitch of 0.15 mm to about 0.25 mm. *Id.* at 9:3–5. Härle does not describe the size of threads 123.

For completeness of discussion, Härle describes its breakage portion 117 as having a circumferential groove. Ex. 2010, 10:10–14. This circumferential groove serves an entirely different purpose than Choi's circumferential groove which is intended to disperse the stress in the cortical bone. Ex. 1005, 9:9–16. Further, with respect to a different embodiment, Härle expressly teaches that breakage portion 17 is designed to be spaced apart from the bone. Ex. 2010, 9:13–15 & Fig. 2. This stands in contrast to Choi, which discloses that its circumferential groove sits inside the bone. *See* Ex. 1005, 9:1–16.

We observe that Choi is a different reference than Härle beyond the fact that Choi's grooves are structurally different than Härle's grooves and serve a different purpose. In addition to providing different structure and function, Choi also provides an advantage, i.e., dispersing stress on the cortical bone, which Petitioner relies on to provide motivation to a person of ordinary skill in the art to add Choi's grooves to the fixture of Westerkull '794. *See* Pet. 44–45. For these reasons, Choi is not cumulative over Härle.

Factors c) and d) The extent to which the asserted art was evaluated during examination, including whether the prior art was the basis for rejection; the extent of the overlap between the arguments made during examination and the manner in which Petitioner relies on the prior art or Patent Owner distinguishes the prior art

(i) Prosecution of the '807 patent

During prosecution of the '807 patent, the applicant filed a terminal disclaimer over U.S. Patent 9,173,042 on October 13, 2017.² Ex. 1009, 58–62. The Examiner issued a notice of allowance on October 25, 2017. Ex. 1009, 22–24.

(ii) Prosecution of the '083 Application

During prosecution of the parent '083 Application, the Examiner issued an Office Action designated as a non-final rejection on September 20, 2011. In that Office Action, the Examiner variously issued prior art rejections under § 102 over Härle, under § 102 over Håkansson '790,³ under § 102 over Niznick,⁴ under § 102 over the Westerkull '222 Application,⁵ under § 102 over the Westerkull '794 Application,⁶ under § 103 over Härle and Huebner,⁷ and Håkansson and Hansson,⁸ and under § 103 over the

² U.S. Patent 9,173,042 to Jinton issued from Application No. 12/177,083 (“the '083 Application”). Ex. 2013, code (21).

³ Håkansson, US 5,735,790 (hereinafter, Håkansson '790).

⁴ Niznick, US 2006/0172257.

⁵ US 2003/0176866, pub. Sept. 18, 2003, based on Application No. 10/332,697, issued as the Westerkull '222 Patent (Ex. 3002, hereinafter, the Westerkull '222 Application). *See* Prelim. Resp. 17.

⁶ US 2006/0093175, pub. May 4, 2006, based on Application No. 10/981,340, issued as the Westerkull '794 Patent (Ex. 3003, hereinafter, the Westerkull '794 Application). *See* Prelim. Resp. 17.

⁷ Hueber, US 6,030,162.

⁸ Hansson, WO 92/05745.

Westerkull '794 Application and the Westerkull '222 Application. Ex. 1010, 305–320.

On April 19, 2012, the Examiner issued an Office Action designated as a final rejection. In that Office Action, the Examiner variously issued prior art rejections under § 102 over Härle, under § 102 over Håkansson, under § 102 over Niznick, under § 102 over the Westerkull '222 Application, under § 102 over the Westerkull '794 Application, under § 103 over Härle and Huebner, Håkansson and Hansson, and the Westerkull '794 Application and the Westerkull '222 Application. Ex. 1010, 222–238.

After a request for continuing examination with an amendment, on June 25, 2014, the Examiner issued an Office Action designated as a non-final rejection. In that Office Action, the Examiner variously issued prior art rejections under § 103 over Håkansson and West, alone or further in view of one of the Westerkull '222 Application, Carter,⁹ the Westerkull '794 Application, Håkansson '790, Huebner, and Hansson. Ex. 1010, 102–109.

On March 4, 2015, the Examiner issued an Office Action designated as a final rejection. In that Office Action, the Examiner also issued set of prior art rejections over Håkansson and West, alone or further in view of one of the Westerkull '222 Application, Carter, the Westerkull '794 Application, Håkansson '790, Huebner, and Hansson. Ex. 1010, 52–59.

The Examiner issued a Notice of Allowance on June 15, 2015. Ex. 1010, 10–12.

(iii) Analysis

Patent Owner argues that similar arguments were considered by the Examiner because the Examiner had rejected claim 29 of the '083

⁹ Carter, US 7,249,949.

Application as anticipated by the Westerkull '794 Publication. Prelim. Resp. 21. Even though Westerkull '794, Westerkull '222, and Håkansson had been considered by the Examiner (at least in terms of the Westerkull '794 Application and the Westerkull '222 Application), Choi was not considered. As we discuss in the preceding section, the teachings of Choi are not cumulative over Härle, contrary to Patent Owner's arguments. Petitioner is relying on Choi for the circumferential grooves. Accordingly, even if Westerkull '794, Westerkull '222, and Håkansson had been considered by the Examiner, the teaching of Choi regarding circumferential grooves was not considered by the Examiner.

Factors e) and f) Whether Petitioner has pointed out sufficiently how the Examiner erred in its evaluation of the asserted prior art; the extent to which additional evidence and facts presented in the Petition warrant reconsideration of prior art or arguments.

Patent Owner argues that Petitioner bears the burden of showing that the Examiner erred in consideration of a reference. Prelim. Resp. 22 (citing, e.g., *Juniper Networks, Inc. v. Mobile Telecomms. Techs., LLC*, IPR2017-00642, Paper 31 at 10–11 n.6 (PTAB Mar. 14, 2018)). Patent Owner contends that Petitioner omitted to mention that the majority of the references cited in the Petition were analyzed during prosecution and that Petitioner does not raise any new evidence or point to any errors to justify reconsideration of the conclusion of patentability. *See* Prelim. Resp. 22–23.

On the record before us, we determine that there was error in the prosecution leading to the issuance of the '807 patent because Choi, with its teaching of circumferential grooves, was not considered. It seems that the Examiner was simply not aware of Choi's teaching in this regard. Although Choi relates to dental implants, Choi deals with similar problems of

implanting a fixture in bone. The Petition therefore presents different prior art than the Office was aware of. On this record, Choi's teachings would have been considered by a person of ordinary skill in the art at the time of filing facing the problem of implanting a fixture in the skull bone. Although the skull bone at issue here is thinner than the corresponding jaw bone for a dental implant, and thus requires shorter implants, it appears that persons of skill in the art of hearing aid implants were cognizant of both types of implants into bone. *See* Ex. 1007, 1:62–65.

Conclusion as to § 325(d)

There is new, noncumulative prior art asserted in the Petition, e.g., Choi. For at least this reason, we determine not to exercise our discretion under § 325(d) to deny the Petition on this basis.

C. Patent Owner's Arguments Regarding 35 U.S.C. § 314(a)

Patent Owner contends that the Board should deny institution under 35 U.S.C. § 314(a) because Petitioner waited a year to file the Petition and used Cochlear's responses in District Court as a roadmap for the Petition; that Petitioner is using this proceeding to stall the district court litigation; and that the Board should not expend its limited resources because the District Court will likely determine the validity of the challenged claims in a similar timeframe. Prelim. Resp. 23–29.

*1. Applicable Precedent*¹⁰

We have discretion to deny a petition for *inter partes* review under § 314(a). *See* 35 U.S.C. § 314(a) (“[t]he Director may not authorize an inter

¹⁰ The statement of applicable precedent in this section is adapted from *Bumble Trading, Inc. v. Match Group, LLC*, IPR2019-00842, Paper 10 (PTAB Sept. 25, 2019).

partes review to be instituted unless”); *Cuozzo Speed Techs., LLC v. Lee*, 136 S. Ct. 2131, 2140 (2016) (“[T]he agency’s decision to deny a petition is a matter committed to the Patent Office’s discretion.”). In a precedential decision, the Board articulated a non-exhaustive list of factors to be considered in evaluating whether to exercise discretion under 35 U.S.C. § 314(a) to deny a petition that challenges a patent that was previously challenged before the Board. *Gen. Plastic Indus. Co. v. Canon Kabushiki Kaisha*, IPR2016-01357, Paper 19 at 15–16 (PTAB Sept. 6, 2017) (precedential). However, the concerns raised by “follow-on petitions” addressed in *General Plastic* are not directly raised by the facts before us because this is the first Petition that Petitioner has filed. *See Kashiv BioSciences, LLC v. Amgen, Inc.*, IPR2019-00791, Paper 15 at 31 (PTAB Sept. 11, 2019) (“the General Plastic factors per se are not directly applicable [to discretionary denial based on parallel litigation as a factor]”) (emphasis omitted).

Nevertheless,

[t]here may be other reasons besides the “follow-on” petition context where the “effect . . . on the economy, the integrity of the patent system, the efficient administration of the Office, and the ability of the Office to timely complete proceedings,” 35 U.S.C. § 316(b), favors denying a petition even though some claims meet the threshold standards for institution under 35 U.S.C. §§ 314(a), 324(a). This includes, for example, events in other proceedings related to the same patent, either at the Office, in district courts, or the ITC.

Office Trial Practice Guide Update (July 2019) (available at <https://www.uspto.gov/sites/default/files/documents/trial-practice-guide-update3.pdf>) (“TPGU”), at 25. For example, in *NHK Spring Co. v. Intri-Plex Technologies, Inc.*, IPR2018-00752, slip op. at 19–20 (PTAB Sept. 12,

2018) (Paper 8) (precedential), the Board denied institution under 35 U.S.C. § 325(d) and also found that “the advanced state of the district court proceeding is an additional factor that weighs in favor of denying the Petition under § 314(a).” In *NHK*, the panel denied institution under 35 U.S.C. § 325(d), finding the asserted prior art and arguments to be the same or similar to those overcome during prosecution. *NHK*, at 18. The panel also found that the “same prior art . . . and arguments” were being advanced in a parallel district court proceeding set for trial within about six months from institution and before any final decision would issue as an additional reason to deny institution under 35 U.S.C. § 314(a). *Id.* at 19. Thus, the § 314(a) inquiry is “a balanced assessment of all relevant circumstances in the case, including the merits.” *TPGU*, 25.

2. Analysis

Patent Owner argues that Petitioner waited a year before filing its Petition. Prelim. Resp. 23–25. However, Patent Owner does not argue that Petitioner has run afoul of the time bar under 35 U.S.C. § 315(b) for Petitions filed more than one year after the service of a district court complaint. *See* 35 U.S.C. § 315(b). According to Patent Owner, the dispute began when Patent Owner filed a complaint on April 13, 2018, in the District of New Jersey against Petitioner, along with a Motion for Preliminary Injunction. Prelim. Resp. 25 (citing Ex. 2015; Ex. 2016). The Petition was filed on April 15, 2019. The complaint was served on April 19, 2018, and April 23, 2018. The Petition was thus timely. *See also NHK*, at 19 (discussing that petition was timely).

Patent Owner contends that Petitioner benefited from Patent Owner’s responses to Petitioner’s invalidity arguments and contentions and used them

as a roadmap for the Petition by adding Choi to counteract a weakness in its District Court invalidity contentions. Prelim. Resp. 25–28. Patent Owner states that it responded to invalidity arguments on July 23, 2018, as part of the briefing on the motion, and further responded to invalidity contentions on October 15, 2018. *Id.* at 23–28. This procedural history cuts in both directions. The Board in *NHK* considered whether delay resulted in any tactical advantage to Petitioner. *See id.* at 19. Taking Patent Owner’s assertions as true, Petitioner may have derived some benefit from seeing Patent Owner’s responses to its invalidity arguments and contentions before filing the Petition.¹¹ In any event, the Board in *NHK* observed that the Petition in that case would have analyzed “the same issues” and therefore the Board proceeding in *NHK* would have been duplicative of the District Court action there. *See NHK* at 19–20. Here, Patent Owner seems to acknowledge that the Board proceeding would not be directly duplicative of the District Court consideration of validity.

Patent Owner also contends that Petitioner is seeking to stall the District Court action. Prelim. Resp. 28–29. However, Patent Owner does not provide any evidence in support of this contention. *See id.* Indeed, we have not been informed of any stay of the District Court action. Accordingly, Patent Owner’s arguments regarding Petitioner’s intentions or the effect of a Board proceeding are speculative.

Patent Owner also argues that the case “is likely to be on the eve of trial or have trial concluded by October 2020,” and that the Board should conserve its resources. Prelim. Resp. 29. However, Patent Owner has not provided the Board with any procedural schedule from the District Court

¹¹ The Motion for Preliminary Injunction was denied. Ex. 3004, 1.

showing a trial date. *See id.* Patent Owner simply informs us that “discovery is well underway.” *Id.*

Weighing the above procedural history, we decline to exercise discretion under § 314(a). We are mindful that a trial in this proceeding would not be directly duplicative of the District Court action. Nor is there a trial date set at the District Court.

3. *Conclusion as to § 314(a)*

On these facts, we decline to exercise discretion under § 314(a) to deny the Petition.

D. Obviousness of Claims 1–12, 14, 16, 25, 28, 33–35, 38, 39, 45, and 46 over Westerkull ’794 (Ex. 1003) and Choi (Ex. 1005)

Petitioner contends that claims 1–12, 14, 16, 25, 28, 33–35, 38, 39, 45, and 46 are unpatentable as obvious over Westerkull ’794 and Choi. Pet. 26–62. Patent Owner opposes. Prelim. Resp. 30–51.

1. *Overview of Westerkull ’794*

Westerkull ’794 is titled “Hearing Aid Anchoring Element” and “relates to an anchoring fixture for anchoring a direct bone-conduction hearing-aid to the skull bone.” Ex. 1003, code (54), 1:5–7.

Westerkull ’794 describes problems with then-existing fixtures. In particular, the diameter of the drilled hole was close to the inner diameter of the thread, such that copious bone shivers were generated. *See id.* at 2:11–19. To accommodate the bone shivers, large shiver cavities were required. *Id.* at 2:19–21. However, it was difficult to have shiver spaces of sufficient depth without interfering with the inner hole of the fixture for the connection of the abutment connection screw. *Id.* at 2:18–25. In addition, the smooth

machined titanium surface did not present optimal properties for osseointegration. *Id.* at 2:26–32.

Poor osseointegration led to clinical problems. Fixtures that lacked proper osseointegration at the beginning required additional procedures, and certain fixtures that osseointegrated became loose due to the mechanical load and also required additional procedures. *Id.* at 2:39–49.

As a solution to the above-identified problems in the art, Westerkull '794 discloses a thread pitch in the range of 0.5 to 0.8 mm, which it states to be optimal for osseointegrated fixtures from a biomechanical point of view. *Id.* at 3:7–9. Westerkull '794 further discloses a thread depth that is at least 10% and not greater than 20% of the maximum diameter of the thread fixture in order to improve grip in bone and also to improve removal forces if such forces are applied to screw out the fixture from the bone. *Id.* at 3:10–26.

Westerkull '794 further discloses that the fixture has at least one cutting edge and each cutting edge has an adjacent cavity where bone shivers may be collected. *See id.* at 4:9–19. Westerkull '794 discloses that the total volume of the cavities may be greater than 50% of the cut off bone volume when the fixture has been screwed into a hole in the bone where the hole has a diameter that is 10% greater than the inner diameter of the thread in order to collect bone shivers. *Id.* at 4:32–39.

Westerkull '794 discloses a preferred embodiment with a titanium oxide layer with a thickness of at least 100 nm on the surface of the threaded portion in order to improve osseointegration. *Id.* at 4:66–5:5. Westerkull '794 discloses that the titanium oxide may include or be covered by other chemical or biological substances to further improve osseointegration. *Id.* at 5:15–18.

Westerkull '794 discloses a preferred embodiment with at least one groove extending at least one turn on the side of the flange facing the threaded portion, which acts as a microthread in contact with the bone to hinder bone resorption under the flange. *Id.* at 5:26–32.

Figure 2 of Westerkull '794 is reproduced below:

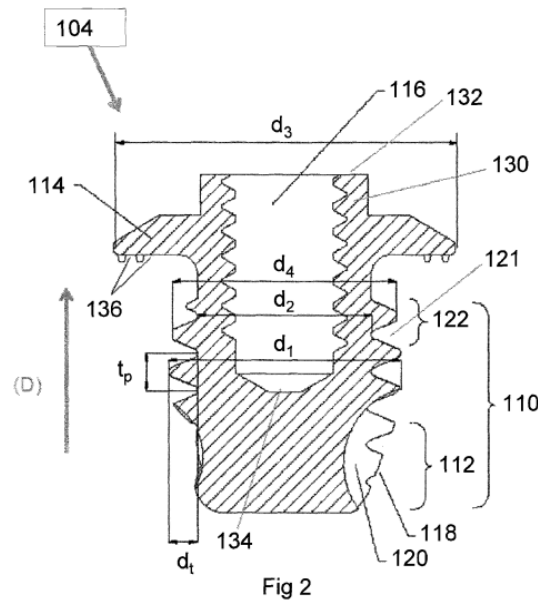

Figure 2 depicts a cross-sectional view of the fixture of Westerkull '794. *Id.* at 5:41–42

2. Analysis

In its Petition, Petitioner sets forth its contentions as to how the limitations of claims 1–12, 14, 16, 25, 28, 33–35, 38, 39, 45, and 46 are disclosed in, or obvious over, the combination of Westerkull '794 and Choi. Pet. 26–62. Petitioner relies on the declaration of Wilson Hayes, Ph.D. Ex. 1002. Patent Owner opposes. Prelim. Resp. 30–51. Patent Owner relies on the preliminary declaration of Mark E. Rentschler, Ph.D. Ex. 2004. We

address these contentions below. We emphasize that the following determinations regarding the sufficiency of the Petition are preliminary in nature at this stage of the proceeding.

a) Claim 1

(i) preamble: “An anchoring fixture for anchoring a prosthesis to a skull bone comprising”; “wherein the anchoring fixture is configured for anchoring a hearing prosthesis component to the skull bone at a location behind an external ear so that sound is transmitted from the hearing prosthesis via the skull bone to the cochlea”

Petitioner asserts, *inter alia*, that the preamble and the wherein clause are not entitled to patentable weight because it recites an intended use. *See* Pet. 19, 24–25. Patent Owner does not separately dispute these recitations. *See* Prelim. Resp. 1–51. Based on our preliminary claim construction in which we agree that the preamble and wherein clause recite an intended use, we need not review the prior art further for this limitation.

For completeness of discussion, Petitioner asserts in the alternative that Westerkull ’794 discloses an anchoring fixture 104 for anchoring a prosthesis to a skull bone. Pet. 47, 49 (citing Ex. 1003, Abstract, 1:5–7; Ex. 1002 ¶¶ 76, 95–96, 139–140). On this record, Petitioner has made an adequate showing. In particular, Westerkull ’794 discloses an anchoring fixture for anchoring a direct bone-conduction hearing-aid to the skull bone. Ex. 1003, 1:5–7. Petitioner, relying on Dr. Hayes’s Declaration, asserts that a person of ordinary skill in the art would understand that a “bone conduction hearing aid” would be anchored to the skull bone at a location behind the ear. Pet. 49 (citing Ex. 1003, 1:13–17; Ex. 1002 ¶ 117). Dr. Hayes points, *inter alia*, to Wazen, which depicts bone-anchored hearing aids in the post-auricular area. Ex. 1002 ¶ 117 (citing, e.g., Ex. 1023, Figs.

1a–1b). On this record, we determine that Wazen¹² shows adequate support for the understanding that a bone conduction hearing aid would have been positioned behind the ear. *See* Ex. 1023, Figs. 1a–1b (depicting placement) and captions thereto.

(ii) *“a screw thread apparatus including a screw thread having a varying outer diameter”*

Petitioner asserts that Westerkull '794 discloses an anchoring fixture 104 includes a screw thread portion 110 with a screw thread 121 having a varying outer diameter. Pet. 47 (citing Ex. 1003, Fig. 2, 5:60–61, 6:15–20; Ex. 1002 ¶¶ 77–78, 97–98, 141). Patent Owner does not separately dispute this limitation. *See* Prelim. Resp. 1–51. On this record, we determine that Petitioner has made an adequate showing. In particular, Westerkull '794 discloses that threaded portion 110 has relieving portion 122 at the distal end and positioned below flange 114 but above outer end 112. Ex. 1003, 6:15–17. Westerkull '794 discloses relieving portion 122 has an outer diameter d_4 that, preferably, is smaller than the maximum outer diameter d_1 of threaded portion 110. *Id.* at 6:18–20.

(iii) *“a flange configured to function as a stop for the anchoring fixture adapted to rest on top of the bone when the anchoring fixture is implanted into the bone”*

Petitioner asserts that Westerkull '794 discloses that anchoring fixture also includes flange 114 configured to function as a stop for the anchoring fixture adapted to rest on top of the bone when anchoring fixture 104 is implanted into the bone. Pet. 47–48 (citing 1003, 5:65–67, Fig. 2; Ex. 1002

¹² Jack J. Wazen et al., *Long-Term Results With the Titanium Bone-Anchored Hearing Aid: The U.S. Experience*, 19 THE AMERICAN JOURNAL OF OTOTOLOGY 737–741 (1998) (Ex. 1023, “Wazen”).

¶¶ 77, 80, 84, 99–100, 145–146). Patent Owner does not separately dispute this limitation. *See* Prelim. Resp. 1–51. On this record, we determine that Petitioner has made an adequate showing. In particular, Westerkull ’794 discloses that an upper end of fixture 104 has radially-outwardly protruding flange 114 with diameter d_3 to prevent fixture 104 from being pushed into the skull. Ex. 1003, 5:65–67.

(iv) “a circumferential groove located, with respect to a side of the flange, on the anchoring fixture on a threaded side of the anchoring fixture”

Petitioner asserts that, to the extent that Westerkull ’794 may be interpreted as not having the claimed circumferential groove, Choi discloses dental implant 200 including a number of circumferential grooves 290 located on a threaded side of the implant with respect to an upper portion of the implant. Pet. 48 (citing Ex. 1005, Abstract, 9:1–16, Figs. 5, 6, 9; Ex. 1002 ¶¶ 90–93, 101, 109–111, 150–152, 174–176, 184, 208, 232). Patent Owner does not dispute that Choi discloses this limitation. *See* Prelim. Resp. 1–51. On this record, we determine that Petitioner has made an adequate showing. In particular, Choi discloses a number of minute screwed grooves 290 formed on the surface of settling portion 230. Ex. 1005, 9:1–2.

Petitioner contends that a person of ordinary skill would have modified Westerkull’s implant by adding Choi’s grooves on the threaded side of the flange because Choi discloses that its grooves improve stability of the fixture, dispersing stress on the implant to the cortex bone, preventing bone loss, and improving bonding of the fixture with bone. Pet. 45–46 (citing, e.g., Ex. 1002 ¶¶ 90, 92, 110, 113, 151, 154, 205, 208–209). Patent Owner argues that Petitioner does not provide an adequate reason to combine the references and does not provide evidence of a reasonable expectation of success. Prelim. Resp. 45–50. Patent Owner asserts that

Westerkull provides larger, deeper grooves and a pitch in the range of 0.5 to 0.8 mm to ensure optimal biomechanical and osseointegration properties, and that Petitioner has not reconciled these teachings with those of Choi. *See id.* at 46–48. At this stage of the proceeding, we do not see a conflict in Petitioner’s reliance on the two references because Choi itself makes use of two kinds of threads. *See Ex. 1005, Fig. 6.* On this record, it is consistent with the teachings of Westerkull ’794 to use the larger threads, as taught by Westerkull ’794, and to add on top of those threads the smaller grooves of Choi, in order to disperse stress in the upper layer of bone, as taught by Choi. *See Ex. 1005, 9:5–7* (“settling portion 230, like a wise crystal module, can disperse the stress on the implant 200 into the cortex-bone of the jawbone and minimize osteolysis so as to increase the bond with the bone”).

Patent Owner also argues that Choi’s dental implant was longer and that Petitioner has not met its burden to show that the two types of threads could have been combined on a smaller skull bone implant. *Prelim. Resp. 49–51* (citing *Ex. 2004 ¶ 55*). However, at this stage of the proceeding, we determine that Petitioner has made an adequate showing that a person of ordinary skill would have made use of the teaching of Choi to incorporate some smaller grooves without bodily incorporation of the length of the implant used in Choi. We note that Westerkull already discloses a thread under the flange of at least one turn. *See Ex. 1003, 5:26–28.* On this record, this turn could have been extended into a full circumferential groove or grooves without an appreciable loss of space for other threads given the small size of the groove taught by Choi. The parties are free to develop the record on this issue further at trial.

Patent Owner asserts that numerous objective indications of nonobviousness, or secondary considerations, weigh against finding the

challenged claims obvious. Prelim. Resp. 30–44. In particular, Patent Owner proffers evidence that allegedly establishes the objective factors: (1) copying; (2) commercial success; (3) long-felt need; and (4) praise. *Id.*

With respect to copying, Patent Owner asserts that petitioner Oticon hired a named inventor of the '807 patent to lead development of Oticon's implant, which Patent Owner alleges to be infringing, and that an internal Oticon presentation shows a "micro groove," which Patent Owner asserts to be evidence of copying along with other internal technical documents. *Id.* at 32–33 (citing Ex. 2002 at 6–8 & Exs. G–J). With respect to commercial success, Patent Owner relies on the Cochlear Baha BI300 implant and the Oticon Ponto BHX implant as embodiments of the '807 patent. *Id.* at 33–42 (citing Ex. 2004 ¶¶ 31–34). With respect to long-felt need and praise, Patent Owner argues that "[n]umerous industry and medical journal articles praised the claimed features of the embodying Cochlear Baha BI300 implant and the infringing Ponto BHX implant for solving the long-felt need of improved ISQ and faster load times." *Id.* at 43 (citing Ex. 2004 ¶¶ 39–44); *see also id.* at 43–44 (citing Ex. 2004 ¶ 42; Ex. 2005, 3). Patent Owner also relies on a study praising the implant stability of the Baha I300 and Oticon Ponto BHX. *Id.* at 43–45 (citing Ex. 2005, 3; Ex. 2006, 3–4; Ex. 2007, 1; Ex. 2004 ¶ 42).

We note that the issue of secondary considerations is highly fact specific. At this stage of the proceeding, the record regarding such secondary considerations is incomplete, and Petitioner has not had the ability to fully respond to the specific arguments raised by Patent Owner in the Preliminary Response. Our final decision will consider the issue of secondary considerations based on the evidence developed during trial as part of our obviousness analysis.

Based on the record at this stage of the proceeding, we determine that Petitioner has established a reasonable likelihood of prevailing on its contentions as to claim 1. In particular, we are mindful of the express teaching in Choi that its grooves dispel stresses in the cortical bone. Ex. 1005, 9:5–7. Petitioner has therefore made an adequate showing that a person of ordinary skill would have sought to add grooves under the flange of Westerkull '794, or expand the existing groove of Westerkull '794, for this reason.

b) Claim 8

Independent claim 8 contains several similar limitations and requirements as independent claim 1, and independent claim 8 additionally recites “a threaded tapered portion, wherein a maximum width of the bone fixture is about the same as a height of the bone fixture.” Ex. 1001, 6:24–26.

Petitioner asserts that Westerkull '794 discloses a fixture diameter in the range of 3.5–5 mm and discloses that the skull bone is usually between 3–5 mm. Pet. 50–51 (citing Ex. 1003, 1:63–66; Ex. 1002 ¶¶ 77, 89, 142, 194–196, 199, 227–229¹³). Petitioner argues that the thickness of the skull bone determines the appropriate length of the fixture and that the width of the fixture would have been about the same as the height of the fixture. *See id.* (citing Ex. 1002 ¶¶ 77, 89, 141–144, 191–196, 224–249). Patent Owner does not separately dispute the additional limitation of claim 8 at this time.

At this stage of the proceeding, Petitioner has provided adequate support for its assertion that the thickness of the skull bone determines the thickness of the fixture. *See* Ex. 1002 ¶ 142. Dr. Hayes relies, *inter alia*, on

¹³ Petitioner refers to both ¶ 229 and ¶ 279. We understand Petitioner to have intended to refer to ¶ 229 because there is no ¶ 279.

the teaching in Westerkull '794 that the flange prevents the fixture from being pushed into the skull. *Id.* (citing Ex. 1003, 5:66–67).

The next question is whether Westerkull '794 teaches or suggests that the width, measured as the maximum or outer width, of the threaded portion and the length of the fixture are about the same, as recited. By way of analogy, we look to the discussion of overlapping items in *In re Petering*, 301 F.2d 676, 682 (CCPA 1962) (“*Petering*”), although we acknowledge that the context is not identical. In *Petering*, the court compared the claim to the prior art and affirmed an anticipation rejection based on overlap therein. In this case, the overlap is between two ranges in a prior art reference for different dimensions of the same object. Nevertheless, the overlap in the ranges for the dimensions may support a finding that it would have been obvious for a person of ordinary skill to have about the same size for the two dimensions. On this record, because the ranges for the width and the asserted limit for the length of the fixture overlap, we determine that Petitioner has made an adequate showing that it would have been obvious to have about the same width and height of the fixture, as recited.

c) claims 2–7, 9– 12, 14, 16, 25, 28, 33–35, 38, 39, 45, and 46

Petitioner sets forth its contentions for claims 2–7, 9– 12, 14, 16, 25, 28, 33–35, 38, 39, 45, and 46. *See* Pet. 52–62. Patent Owner does not separately dispute these limitations. On the record at this stage of the proceeding, and based on our independent review of the evidence, we determine that Petitioner has established a reasonable likelihood of prevailing on its contentions as to 2–7, 9– 12, 14, 16, 25, 28, 33–35, 38, 39, 45, and 46.

E. Obviousness of Claim 17 over Westerkull '794, Choi, and Håkansson (Ex. 1006)

Petitioner contends that claim 17 is unpatentable as obvious over Westerkull '794, Choi, and Håkansson. Pet. 63–68. Patent Owner opposes. Prelim. Resp. 51.

1. Overview of Håkansson

Håkansson is titled “A Device for Anchoring and Energy Transfer at Implants” and relates to a device at implants for anchoring in bone tissue and supporting of a prosthesis or transfer of electrical and/or mechanical energy from a transmitter or the like to the implant via a coupling device, which incorporates a first and a second coupling part. Ex. 1006, code (54), 1:7–10. Håkansson describes a problem in the prior art with two-piece implants, i.e., high manufacturing costs and the requirement for high tolerances for the internal fitting of the parts, in particular for signal transferring applications. *Id.* at 2:8–12. Håkansson, *inter alia*, discloses a device where a coupling part and flange fixture are made integral so that the operation can be carried out in one stage and the device can be used to the full extent after a healing period of a few weeks. *Id.* at 5:1–5.

Figure 1 of Håkansson is reproduced below:

FIG. 1

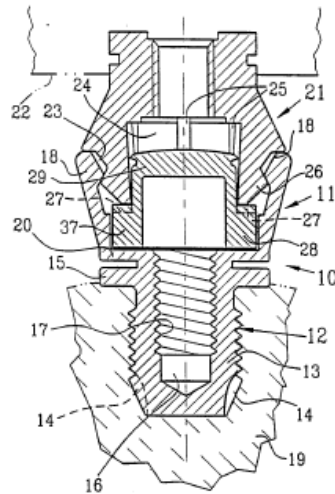

Figure 1 of Håkansson shows a longitudinal section through an embodiment of an implant with added apparatus coupling part. Ex. 1006, 3:8–9.

2. Analysis

Claim 17 depends from claim 1 and further recites:

wherein: a cross-section of the fixture lying on and parallel to a longitudinal axis of the anchoring fixture has, on one side, with respect to location from a proximal end to a distal end of the fixture, starting at a location of maximum screw thread radius on the one side, six turns inclusive of the turn having the maximum screw thread radius.

Ex. 1001, 7:23–29. Petitioner argues that fixture 12 of Håkansson has six turns, as depicted in Figure 1 of Håkansson. Pet. 65–66. On this record, Petitioner has made an adequate showing that the outer threads of item 12 are depicted as having 6 turns. *See* Ex. 1006, Fig. 1. Petitioner argues that having six threads would have been an obvious variation to the device of Westerkull '794 because the number of threads is a result-effective variable that is a factor in determining the stability of a fixture. Pet. 67 (citing Ex. 1002 ¶¶ 239–245). Patent Owner does not separately dispute this limitation.

On this record, we are persuaded that Petitioner has made an adequate showing. In particular, Dr. Hayes testifies that a person of ordinary skill would have recognized the number of screw threads as a result-effective variable in determining the stability of a fixture. *See* Ex. 1002 ¶ 244. We determine that Petitioner has established a reasonable likelihood of prevailing on its contention that it would have been obvious to modify further the device of Westerkull '794 in view of Håkansson to use six screw threads for the fixture.

F. Obviousness of Claims 37 and 47 over Westerkull '794, Choi, and Westerkull '222 (Ex. 1007)

Petitioner contends that claims 37 and 47 are unpatentable as obvious over Westerkull '794, Choi, and Westerkull '222. Pet. 68–71. Patent Owner opposes. Prelim. Resp. 51.

1. Overview of Westerkull '222

Westerkull '222 is titled “Anchoring Element” and relates to a screw-shaped anchoring element (fixture) for permanent anchorage of hearing aid devices or extraoral prostheses in the form of ear and orbital prostheses in the skull bone, which is thinner than the jaw bone. Ex. 1007, code (54), 1:5–8. Westerkull '222 describes that dental implants are too long for the skull bone and cannot be installed without the use of screw taps. *Id.* at 1:58–67. Westerkull '222, *inter alia*, discloses a self-tapping screw for anchoring in comparatively thin skull bone. *Id.* at 2:5–8.

2. Analysis

Claim 37 and 47 depend respectively from claims 1 and 8 and further recite “wherein: the flange has a maximum diameter that exceeds a peak diameter of the thread by approximately 10-20%.” Ex. 1001, 9:41–43, 10:42–44. Petitioner asserts that Westerkull '222 describes that its flange 7

has a diameter which exceeds the peak diameter of the threads with 10–20%. Pet. 70 (citing Ex. 1007, 3:12–14; Ex. 1002 ¶ 252). Patent Owner does not separately dispute this limitation. On this record, Petitioner has made an adequate showing. In particular, Westerkull '222 discloses that the flange has a diameter which exceeds the peak diameter of the threads with 10–20%. Ex. 1007, 3:12–14.

Petitioner argues that it would have been obvious to modify the device of Westerkull '794 to have such a flange diameter because a person of ordinary skill would have recognized that it was desirable for the flange to have sufficient diameter to function as a stop for the anchoring fixture. Pet. 71 (citing Ex. 1002 ¶¶ 253).

On this record, we are persuaded that Petitioner has made an adequate showing. In particular, Dr. Hayes testifies that it would have been desirable to design a flange to function as a stop and that adapting the flange of Westerkull '794 by this amount would have involved nothing more than combining known prior art elements in known ways with no change to their respective functions. *See* Ex. 1002 ¶ 253. We, therefore, determine that Petitioner has established a reasonable likelihood of prevailing on its contentions as to claims 37 and 47.

G. Obviousness of Claims 28, 40, and 41 over Westerkull '794, Choi, and Brånemark (Ex. 1008)

Petitioner contends that claims 28, 40, and 41 are unpatentable as obvious over Westerkull '794, Choi, and Brånemark. Pet. 71–75. Patent Owner opposes. Prelim. Resp. 51.

1. Overview of Brånemark

Brånemark is titled “An Implant and an Implant Member” and relates to an implant comprising means for attachment to living biological tissue of

a human being or an animal, the implant having an outer surface comprising a first part and a second part which have different properties with regard to the biocompatibility of each part with biological tissue, and to a method for producing such an implant, and to a masking unit used in said method. Ex. 1008, code (54), 1:3–8. Brånemark describes that the use of titanium and titanium alloys was limited to tissue of good quality. *Id.* at 1:25–29.

Brånemark, *inter alia*, discloses an implant comprising a surface portion of a ground surface and one or more several delimited regions making up a second part. *Id.* at 2:28–30. Brånemark discloses that the heterogeneous structure of the surface provides the possibility to tailor the interaction of an implant with different specific biological systems. *Id.* at 3:6–8.

2. Analysis

a) Claim 28

Claim 28 depends from claim 1 and further recites “wherein: a portion of a surface of the fixture that contacts bone has a modified increased surface roughness relative to another portion of the surface of the fixture that contacts bone.” Ex. 1001, 8:27–31. Petitioner asserts that Brånemark discloses the use of surface roughening to enhance interaction with biological tissue (citing Ex. 1008, 6:14–19, 6:23–32), that Brånemark discloses the adding deposits of hydroxyapatite to delimited areas of the anchor that are in direct contact with bone (citing Ex. 1008, 7:10–16, 8:29–9:1), and that a person of ordinary skill would understand that hydroxyapatite would have increased the surface roughness relative to titanium (citing Ex. 1002 ¶ 262). Pet. 73. Petitioner argues that a known advantage of adding hydroxyapatite to the bone anchoring fixture was to improve biocompatibility of the anchoring fixture. *Id.* at 74 (citing Ex.

1008, 7:10–16; Ex. 1002 ¶¶ 261–263). Patent Owner does not separately dispute this limitation. *See* Prelim. Resp. 51.

On this record, we are persuaded that Petitioner has made an adequate showing. In particular, Brånemark discloses that deposits of hydroxyapatite would have been advantageous. *See* Ex. 1008, 8:29–9:1. Dr. Hayes avers that a person of ordinary skill would understand that the hydroxyapatite deposits increases the surface roughness compared to the regions without hydroxyapatite. Ex. 1002 ¶ 262. We, therefore, determine that Petitioner has established a reasonable likelihood of prevailing on its contentions as to claim 28.

b) Claims 40 and 41

Petitioner relies on similar evidence for claims 40 and 41. *See* Pet. 71–74. Patent Owner does not separately dispute these limitations. Based on our independent review of the evidence, we determine that Petitioner has established a reasonable likelihood of prevailing on its contentions as to claims 40 and 41, for similar reasons as for claim 28.

III. CONCLUSION

We conclude that Petitioner has demonstrated a reasonable likelihood of prevailing on its assertion that claims 1–12, 14, 16, 17, 25, 28, 33–35, 37–41, and 45–47 of the '807 patent are unpatentable.

IV. ORDER

In consideration of the foregoing, it is hereby:

ORDERED that, pursuant to 35 U.S.C. § 314(a), an *inter partes* review of claims 1–12, 14, 16, 17, 25, 28, 33–35, 37–41, and 45–47 of the '807 patent is instituted with respect to all grounds set forth in the Petition (*see* Section I.E., *supra*);

IPR2019-00975
Patent 9,838,807 B2

FURTHER ORDERED that pursuant to 35 U.S.C. § 314(c) and 37 C.F.R. § 42.4, notice is hereby given of the institution of a trial commencing on the entry date of this Decision.

IPR2019-00975
Patent 9,838,807 B2

For PETITIONER:

D. Richard Anderson
Lynde Herzbach
Chad Wells
Jason Rhodes
BIRCH, STEWART, KOLASCH & BIRCH, LLP
dra@bskb.com
lynde.herzbach@bskb.com
cdw@bskb.com
jwr@bskb.com

For PATENT OWNER:

Harper Batts
Chris Ponder
SHEPPARD, MULLIN, RICHTER & HAMPTON LLP
hbatts@sheppardmullin.com
cponder@sheppardmullin.com